



Swann[™]

English



Varifocal IP Camera
for use with Full HD *Swann* NVRs

NHD_830_831CAM_131113E

Warranty Information, Verifications & Warnings

Swann Communications warrants this product against defects in workmanship and material for a period of one (1) year from its original purchase date. You must present your receipt as proof of date of purchase for warranty validation. Any unit which proves defective during the stated period will be repaired without charge for parts or labor or replaced at the sole discretion of Swann. The end user is responsible for all freight charges incurred to send the product to Swann's repair centers. The end user is responsible for all shipping costs incurred when shipping from and to any country other than the country of origin.

The warranty does not cover any incidental, accidental or consequential damages arising from the use of or the inability to use this product. Any costs associated with the fitting or removal of this product by a tradesman or other person or any other costs associated with its use are the responsibility of the end user. This warranty applies to the original purchaser of the product only and is not transferable to any third party. Unauthorized end user or third party modifications to any component or evidence of misuse or abuse of the device will render all warranties void.

By law some countries do not allow limitations on certain exclusions in this warranty. Where applicable by local laws, regulations and legal rights will take precedence.

For Australia: Our goods come with guarantees which cannot be excluded under Australian Consumer Law. You are entitled to a replacement or refund for a major failure and for compensation for any other reasonably foreseeable loss or damage. You are also entitled to have the goods repaired or replaced if the goods fail to be of acceptable quality and the failure does not amount to major failure.

Warning

Modifications not approved by the party responsible for compliance could void user's authority to operate the equipment.

IMPORTANT SAFETY INSTRUCTIONS

- Make sure product is fixed correctly and stable if fastened in place
 - Do not operate if wires and terminals are exposed

IMPORTANT NOTE: All jurisdictions have specific laws and regulations relating to the use of cameras. Before using any camera for any purpose, it is the buyer's responsibility to be aware of all applicable laws and regulations that prohibit or limit the use of cameras and to comply with the applicable laws and regulations.

FCC Verification

Note: This equipment has been tested and found to comply with the limits for Class B digital device, pursuant to part 15 of the FCC Rules. These limits are designed to provide reasonable protection against harmful interference in a residential installation. This equipment generates, uses and can radiate radio frequency energy and, if not installed and used in accordance with the instructions, may cause harmful interference to radio or television reception, which can be determined by turning the equipment off and on, the user is encouraged to try to correct the interference by one or more of the following measures:

- Reorient or relocate the receiving antenna
- Increase the separation between the equipment and the receiver
- Connect the equipment into an outlet on a circuit different from that to which the receiver is connected
- Consult the dealer or an experienced radio/TV technician for help

These devices comply with part 15 of the FCC Rules. Operation is subject to the following two conditions:

- These devices may not cause harmful interference, and
- These devices must accept any interference received, including interference that may cause undesired operation.

Introduction

Congratulations on your decision to purchase this **varifocal*** *Swann* HD IP camera! Whether you've chosen the standard case or the dome form factor, this is an excellent addition to your *Swann* NVR monitoring solution.

IMPORTANT: This camera is intended for use with a Full HD-capable *Swann* NVR, such as the NVR-7200/7250 series.

This camera can work as a stand-alone IP camera, but may not be compatible with any other NVR or network video device.

If you are looking for instructions on how to use these cameras as a stand-alone IP camera solution, you can find information on our website, www.swann.com.

Where to Begin?

This short manual will walk you through the **connection, mounting, aiming and lens configuration** of your camera, as well as suggest some tips and tricks for placing your cameras and designing your system.

If you have any trouble, look towards the end of the booklet where you'll find a short **troubleshooting guide**, as well as **technical support details**.

**What does "varifocal" mean? A variable focus lens allows you to zoom the camera's view in and out. It's like a zoom lens on a digital camera, but it's pretty rare for CCTV systems to feature varifocal lenses. We've included them here on these cameras because we think it makes them suitable for a huge range of locations and applications.*

Connection Guide

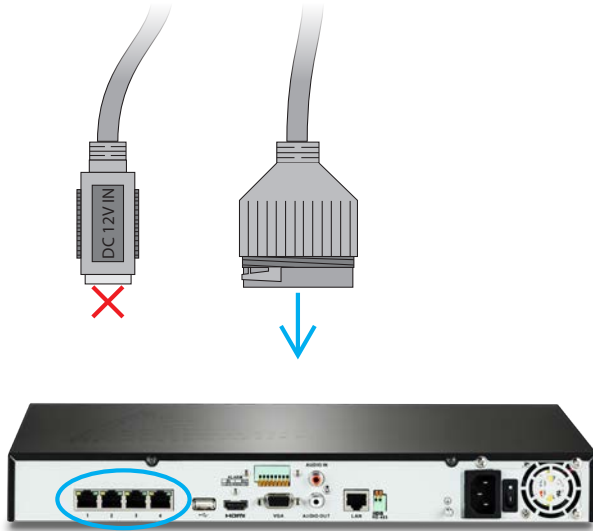

Top, from left to right: **DC 12V Input** and **Network Video Port** (Video Out).

Required Connections

Network Port (Video Out): The main connection for the camera. This connects using the included CAT5E cable to one of the Network Video Inputs on the rear of the NVR (see your NVR manual for additional details). This is the only required connection when connecting the camera to a Swann PoE NVR.

We do not recommend or support the use of any cables other than those supplied with your camera/NVR, nor modifying the supplied cables.

Optional: Advanced Users Only

DC 12V Input: The camera is intended to be powered via PoE (*Power over Ethernet*). This means you will **not** have to connect this port when the camera is directly connected to a Swann NVR supporting PoE (such as the NVR-7200 series).

If you are connecting the camera to your NVR via additional network hardware such as switches and routers that do not support PoE then you can power the camera using this DC 12V input.

Note that using this method will require advanced networking knowledge to set up the camera successfully on your NVR.

Cable Management

When connecting your cables:

1. **Never place strain of any kind on the network cable connection.** It's designed to clip into place to prevent slippage, but it won't support any weight and can easily be broken by a sharp tug. Exercise caution.
2. **Ensure that all cables are sheltered from moisture, weather and sunlight.** The network cable connection was designed and intended for indoor use with computer networking - while it's ideal for handling the massive data loads that network cameras require, it's not weatherproof. The use of conduit piping, silicone sealant and intelligent placement under shelter are highly recommended.

We recommend installing the camera cable into a location sheltered from the weather - in addition to making cable management significantly easier, it also has the advantage of prolonging the life of the camera - while the camera is sealed, robust and able to handle the weather, long-term exposure to temperature fluctuations, direct sunlight (particularly UV) and moisture will eventually cause a degradation in performance.

There are some times however, that it's essential to mount a camera somewhere with no protection from the elements and nowhere to tuck the cable out of harms way. If that's the case for your application, then read below.

Optional: Advanced Users ONLY

The Waterproof Plug Cover: If you're comfortable terminating RJ45 cable, then you can install the waterproof plug cover.

1. **Slip** an unterminated segment of RJ45 through the waterproof plug cover.
2. **Terminate** the RJ45 with a network plug.
3. **Insert** the screw thread into the other side of the plug cover, and **twist** to secure.

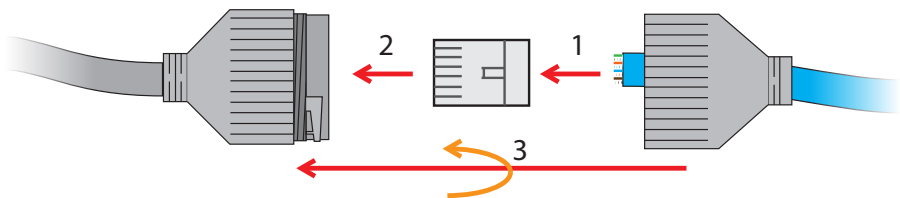

Note: This is an advanced procedure, no matter how simple that diagram looks.

We can't guarantee or warrant any modified cables or connections.

Note: If you are using the supplied CAT5E cable we recommend you seal the camera connection with electrical tape, shrink tube or silicone sealant to prevent the connection deteriorating from moisture entering the pins.

Mounting the Camera: Standard Housing

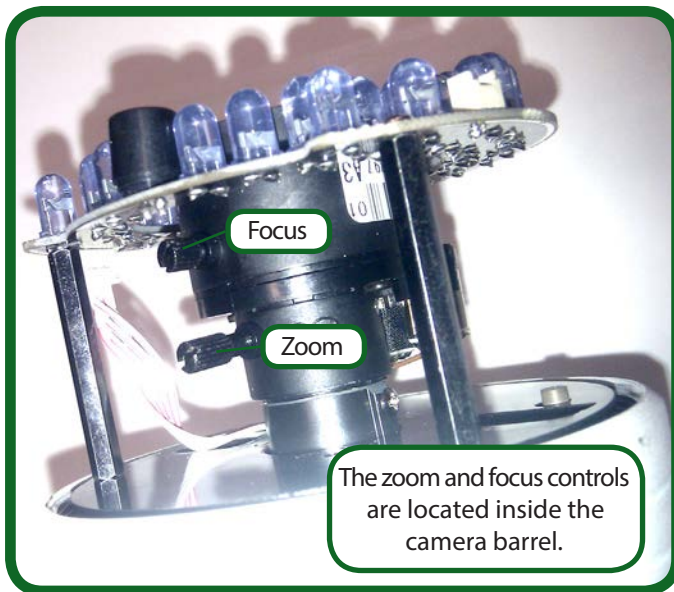
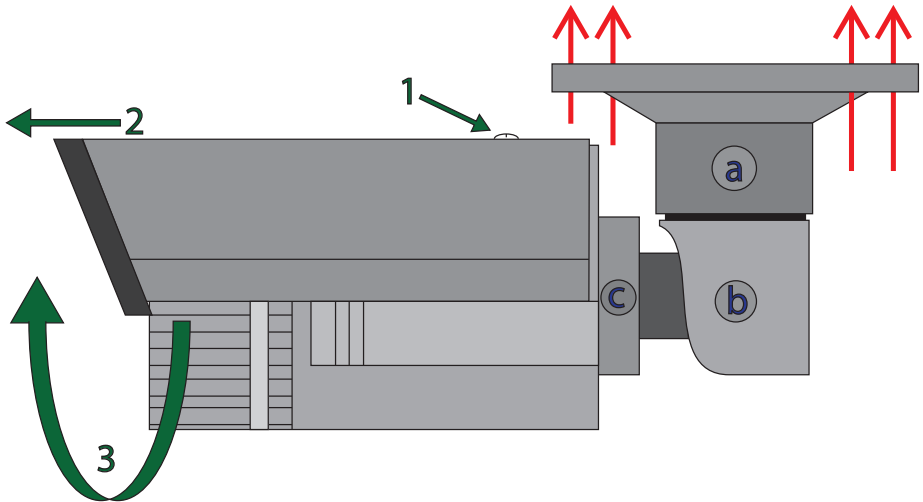

Stage 1: Attach to a wall or ceiling with the supplied screws

- Use four screws to mount the camera, as indicated by the **red arrows** on the diagram opposite.
- Ensure that the surface you're mounting the camera to has sufficient strength to hold it safely.
- For wooden surfaces, then use the supplied screws. We recommend drilling guide holes for any hardwood mounting.
- If you're mounting to masonry, use the supplied wall plugs.

Step 2: Aim the Camera

The three points marked **a**, **b** and **c** on the diagram opposite are the pivot points for aiming the camera. Each is held in place by a small screw with a star-head - use the supplied star-key to loosen the screw, adjust the stand as required and then retighten the screws.

The star-key screws add extra security to your camera mounting, as it's impossible to turn them with a regular screwdriver.

Step 3: The Zoom and Focus Controls

To access the zoom and focus controls...

1. Using a Phillips head screwdriver, loosen the screw on top of the camera's hood.
2. Remove the hood.
3. Turn the front part of the barrel counter-clockwise to remove it. The zoom and focus controls are located inside.

To adjust the zoom and focus controls...

- You'll need to be able to see a live output from the camera while you're working. The best solution is often to bring the NVR and a monitor/television out to where you're working, or you can use a mobile device running the *SwannView Plus* app.
- Loosen the two locking screws shown on the diagram (opposite) but don't remove the screw entirely.
- First, set the zoom to the level you desire. This will be determined by how large an area you want to monitor, and how far away the camera you require detail to be clearly visible. Everything will be really blurry until the camera is focused.
- Now, focus the camera by adjusting the position of the focus ring. Move the ring slowly until the image becomes sharp - for the best focus, go *past* this point slightly, and then back again in smaller increments each time in order to find the exact "centre point" of the focus.
- You might notice that adjusting the focus slightly changes the zoom - this is normal.
- Tighten the screws to lock the lens in place.

Mounting the Camera: Dome Housing

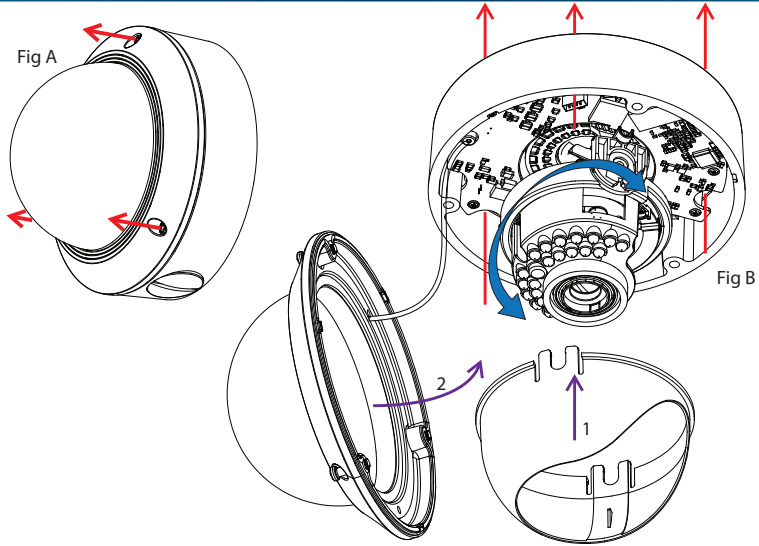
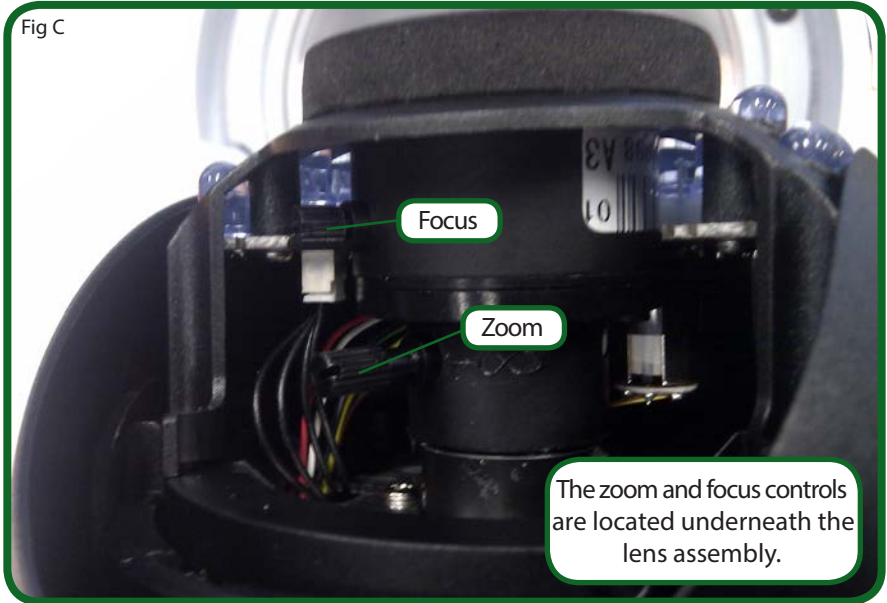

Fig C



Step 1. Attach to a wall or ceiling with the supplied screws

- As shown in *Fig A*, use the supplied star-key to remove the screws holding the top of the dome in place.
- Locate the mounting holes with rubber O rings, indicated by the red arrows on *Fig B*.
- For wooden surfaces, use the supplied screws. We recommend drilling guide holes using the template in the pack for any hardwood mounting.
- If you're mounting to masonry, use the supplied wall plugs.

Step 2. Aim the Camera

The camera itself is mounted on an adjustable platform within the dome. Once the camera is mounted, you can change the way the camera faces by adjusting this platform. Exercise care - it's not as robust as the outside of the dome!

Step 3. The Zoom and Focus Controls

The zoom and focus controls are located beneath the lens itself as shown in *Fig C*.

To adjust the zoom and focus controls...

- You'll need to be able to see a live output from the camera while you're working. The best solution is use a mobile device running the *SwannView Plus* app.
- Loosen the two locking screws shown on the diagram (opposite) but don't remove the screw entirely.
- First, set the zoom to the level you desire. This will be determined by how large an area you want to monitor, and how far away from the camera you require detail to be clearly visible. Everything will be really blurry until the camera is focused.
- Now, focus the camera by adjusting the position of the focus ring. Move the ring slowly until the image becomes sharp - for the best focus, go *past* this point slightly, and then back again in order to find the exact "centre point" of the focus.
- You might notice that adjusting the focus slightly changes the zoom - this is normal.
- Tighten the screws to lock the lens in place.

Step 4. Reassembling the Dome

When you've aimed the camera and set the zoom and focus, replace the black interior dome hood (1) and then the dome cover (2) and secure the star-key screws.

1. **Ensure that the interior dome cover is securely replaced and isn't obstructing the lens** - if it's out of place, the IR light from the active night vision can reflect back into the lens and wash out the picture.
2. **Likewise, ensure the soft seal around the front of the lens housing is pressed firmly against the clear part of the dome when resealing**, otherwise the night vision might blind the camera.

Installation Tips and Tricks

Choosing a Location

The Varifocal cameras are very flexible, and can be installed practically anywhere. Some of the things you'll have to consider when choosing a location are:

- What you want to monitor, and where you'll get the best view of it.
- How you're going to connect the camera to your monitoring system. Remember that cables and connections should be kept out of the weather.
- How to keep the camera out of harm's way. Up high in protected corners is a good option.

Rules is Rules

Regardless of all the tweaking of the lens and image processing you do, there are a few immutable things that are true for all cameras, *Full HD* or otherwise.

- The closer the camera is to what you want to see, the more detail you're going to get. Full HD is a gloriously high-definition picture, but reality has near infinite resolution! You can gain some detail by tweaking the zoom, but this comes at the cost of viewing area - there's no substitute for proximity.
- Areas with varied lighting conditions are hard to view completely, with any camera. If the bright bits are exposed correctly, then the shadows will "black out". If the shadowy areas are exposed correctly, then the bright bits will overexpose and "white out". Aiming the camera at an evenly lit area will always give the best results.
- That "image enhancement" stuff that they do on CSI is all lies. You can't zoom in indefinitely on a video image. Licence plates are only readable from a dozen meters (a few dozen or so feet) away - the exact distance depends on the amount of zoom applied. If someone's head is represented by three pixels, that's it. Sorry. This is technology, not magic. This is a great CCTV camera, but it's still just a video camera - it can't see that much better than you can! Still, it does make for good television.

Troubleshooting

Q: I can't see anything at night!

A: There are a few possible solutions to this problem. Here are some of the most common.

- If the image is mostly black, then this may indicate that the night vision isn't turning on. A bright light source somewhere in the picture can fool the light sensor into thinking it's still daytime - try re-aiming the camera.
- If the image is mostly white, then this indicates that the IR light from the night vision is bouncing back into the lens. If you're using the dome version of the camera, ensure that the lens is protected from reflected IR light by the interior dome cover and the rubber seal around the lens.
- IR light from the night vision can also be reflected back into the camera by glass, perspex, otherwise transparent plastics and spider's webs. Ensure that the camera's viewing area is free from these obstructions - if you want to see outside, then the camera itself needs to be outside!

Q: The NVR is not detecting the camera.

A: If you are using PoE, ensure that the connection between the camera and NVR is direct - i.e. no hubs, switches, adapters or other devices. Ensure you're using only the supplied cable. Ensure that all cables are properly connected and secure. If this doesn't work, try using a different channel on the NVR - reboot the system between connections to ensure a proper IP address refresh. If this doesn't work, then try a different network cable - there may be a breakage.

Q: Everything looks blurry/soft.

A: You probably need to adjust the focus (see the mounting/aiming instructions). This is simply a matter of removing the appropriate control screw one way until you find the best focus point or it won't turn any more. Then, turn it back the other way. If there is no "sweet spot" then this indicates one of two things.

1. Your lens might be dirty. Clean the front of it with a dedicated lens cleaning cloth (available at any camera store). Avoid using solvents or cleaning chemicals, as these can leave a residue.
2. You might be trying to focus on something outside the "depth of field" - objects need to be at least a certain distance from the camera for you to be able to focus on them. Typically, this will be only a few feet (about 1m) but this distance can increase dramatically if the lens is zoomed in, or in low light conditions.
3. Be sure to properly re-seal the camera housing after adjusting either the zoom or the focus!



Helpdesk / Technical Support Details

Swann Technical Support
All Countries E-mail: tech@swann.com

Telephone Helpdesk

USA toll free
1-800-627-2799

AUSTRALIA toll free
1300 133 324

USA Exchange & Repairs
1-800-627-2799 (Option 1)
(M-F, 9am-5pm US PT)

NEW ZEALAND toll free
0800 479 266

UK
0203 027 0979